

NOTES:

1. VARIATION OF SIGN & 4
2. RELOCATED TO TRADITIONAL BUILDING OR ROUNDING CORNER,
3. SIGN TO FACE WITH AREA BOUND OR PARKING AREA SIGN SHOULD RELOCATE TO LARGER BUILDING OR SITE USE,
4. SIGN SET IN LANDSCAPED AREA OR FRONT YARD,
5. PAINTING AREA REQUIRED WITHIN LANDSCAPED YARD; 120 SQ. FT. =
6. COLORS AND MATERIALS TO COMPLEMENT BRG, DESIGN,
7. MATERIALS CONSIDERED: WOODEN SIGN PAINTED OR STAINED,
8. CONCRETE BASE AND BRICK STRUCTURE WITH ATTACHED OR FREESTANDING WOODEN SIGN,

TRADITIONAL DESIGN 4'-8' BRICK WALL

FREESTANDING SIGN 5  
 DESIGN ALTERNATIVES  
 CANTON CHAMBER OF COMMERCE

DATE: JULY 30, 1982  
 DICK SANGER, PRESIDENT  
 CHAMBER OF COMMERCE  
 JACK ST PIERRE, CHAIRMAN ROUTE 44  
 SIGN COMMITTEE

LANDSCAPE ARCHITECTS: LAODA COLLINSVILLE, CONNECTICUT

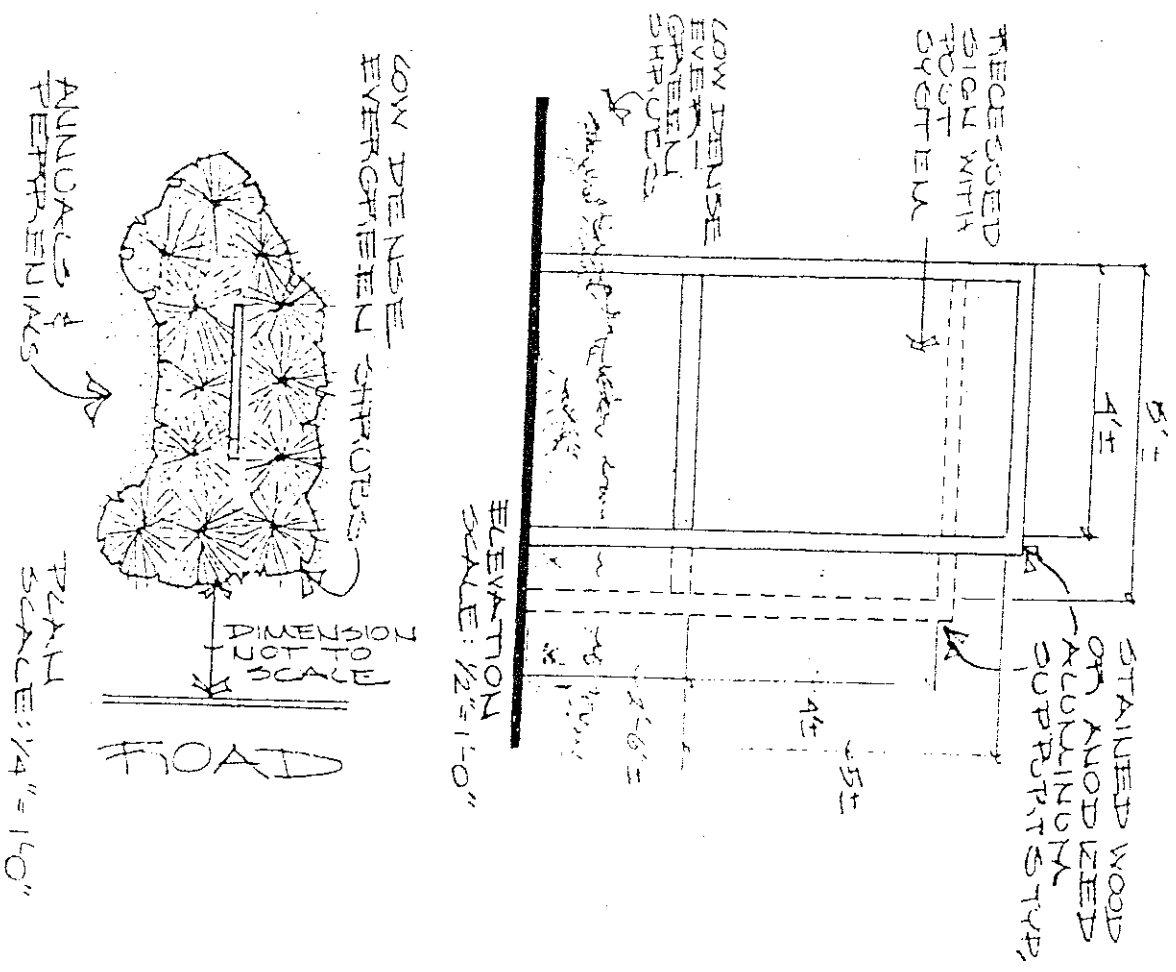

NOTES:

1. MATERIALS TO CONTEMPORARY DESIGN BUILDING OR BUILDING COMPLETE
2. SIGN TO FACE EITHER ROAD OR PARKING AREA
3. SIGN SIZE SHOULD BE ADJUSTED TO SCALE OF MEDION SIDE BUILDING OR SITE
4. SIGN SET IN LANDSCAPED AREA OF FRONT YARD
5. PLANTING AREA REQUIRED WITHIN LANDSCAPED YARD: 80 SQ. FT. =
6. COORDINATE MATERIALS TO SURROUNDING BLDGS, DESIGN
7. MATERIALS CONSIDERED: WOOD, METAL, OR FIBERGLASS, FACE WOOD OR ALUMINUM SUPPORTS, LETTERING TO BE ATTACHED TO SURFACE OR ENGRAVED, ETCHED, OR CARVED,

CONTEMPORARY 4'x5' (VERT) 5'x4' (HORIZ)

FREESTANDING SIGN DESIGN ALTERNATIVES CANTON CHAMBER OF COMMERCE

DICK SANGER, PRESIDENT CHAMBER OF COMMERCE JACK ST PIERRE, CHAIRMAN

DATE: JULY 20

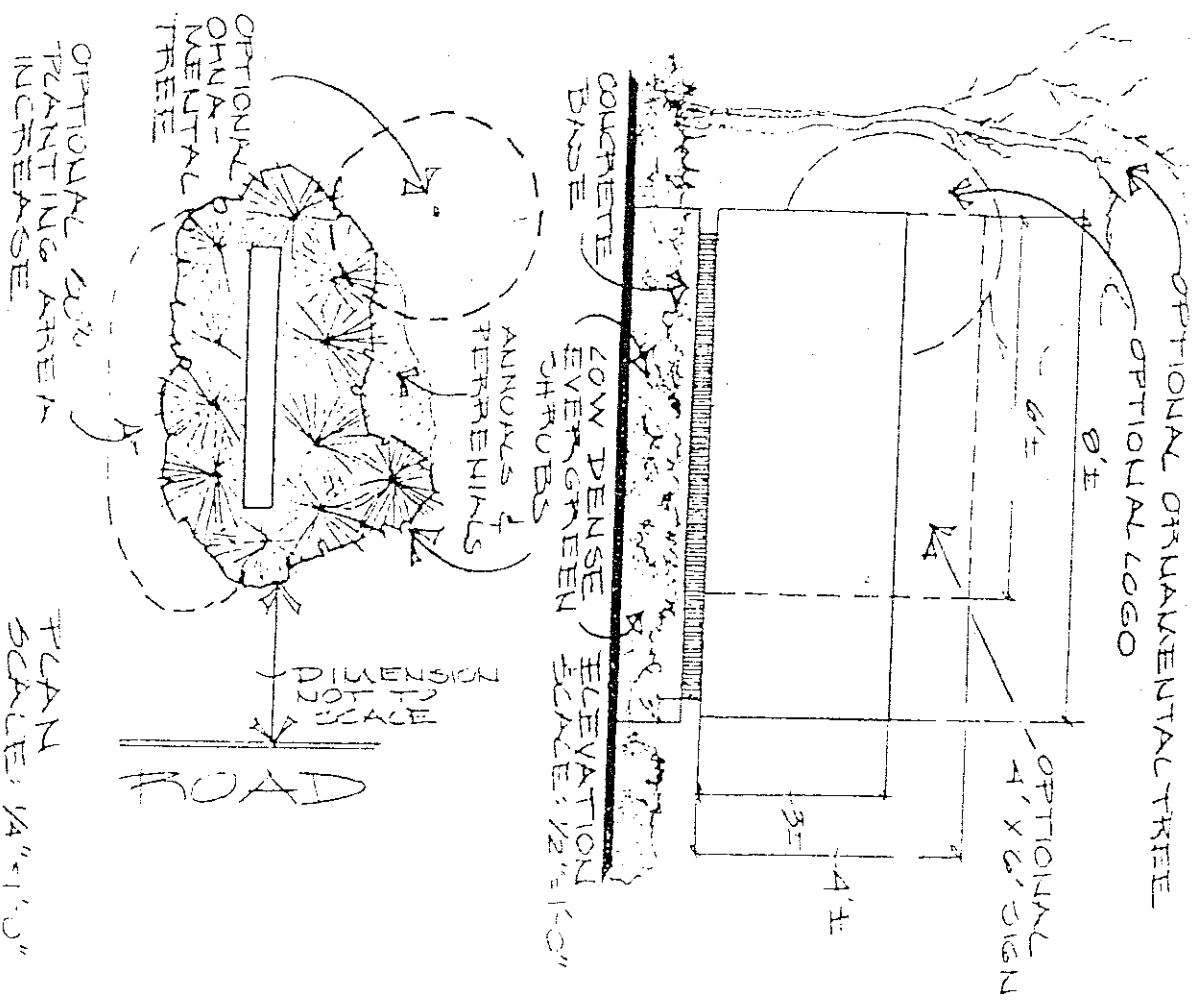

PLAN SCALE: 1/4" = 1' 0"

NOTES:

1. PRECISE TO CONTEMPORARY DESIGN BUILDING COMPLEX.
2. SIGN TO FACE EITHER FRONT OR BACKING AREA.
3. SIGN SHE SHOULD BE CUT TO MEDIUM SIZE BUILDING OF SITE.
4. SIGN SET IN SAND BOARD ISLAND ON FRONT YARD.
5. PAINTING AREA REQUIRED WITH SAND BOARD WARD: 100 SQ. FT. ±
6. COLORS AND MATERIALS TO COMPLEMENT BLDG. DESIGN.
7. MATERIALS CONSIDERED:
8. WOOD, METAL, OR FIBERGLASS FACE, CONCRETE BASE, LETTERING TO BE ATTACHED TO THE OTHER FACE OF ENGRAVED, ETCHED, OR CARVED.

CONTEMPORARY 3'x8' OR 4'x6' W/LOGO

FREESTANDING SIGN 7 DESIGN ALTERNATIVES

DICK SANGER, PRESIDENT CHAMBER OF COMMERCE JACK ST PIERRE, CHAIRMAN

DATE: JULY 30,

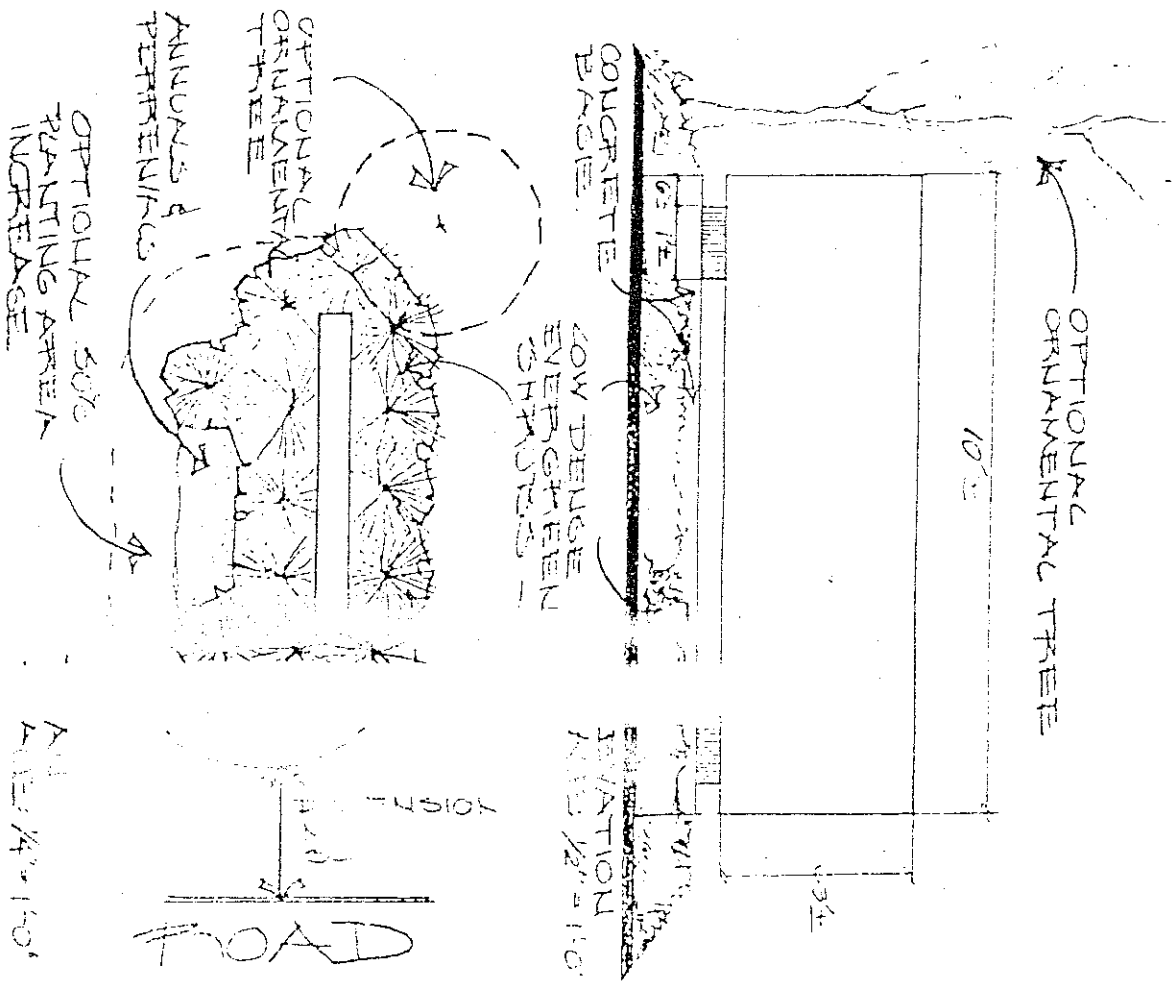

NOTES:

- 1 RELATES TO CONTEMPORARY DESIGN OF BUILDING, OR BUILDING COMPLETE, OR BUILDING
- 2 SIGN TO FACE EITHER ROAD OR PARKING AREA,
- 3 SIGN SIZE SHOULD RELATE TO LARGE BUILDING OR SITE,
- 4 SIGN SET IN SAND-SCAPED ISLAND OR MOUNTAINS,
- 5 PLANTING AREA REQUIRED WITHIN SANDSCAPED MOUNTAINS: 120 SQ. FT. =
- 6 BUSHES AND WATERING TO SUPPLEMENT BUSHES,
- 7 MATERIALS SHOULD BE WOOD, METAL, CONCRETE, OR FIBERGLASS FACE, CONCRETE BASE, CENTERING TO BE ATTACHED TO SURFACE OR ENGRAVED, ETCHED, OR CARVED,

CONTEMPORARY 8' x 10'

LANDSCAPE ARCHITECTS, L.A.P.C. COLLINSVILLE CONNECTICUT

FREESTANDING SIGN DESIGN ALTERNATIVES CANTON CHAMBER OF COMMERCE

DICK SANGER, PRESIDENT CHAMBER OF COMMERCE JACK ST PIERRE, CHAIRMAN ROUTE 44

DATE: JULY 30, 19

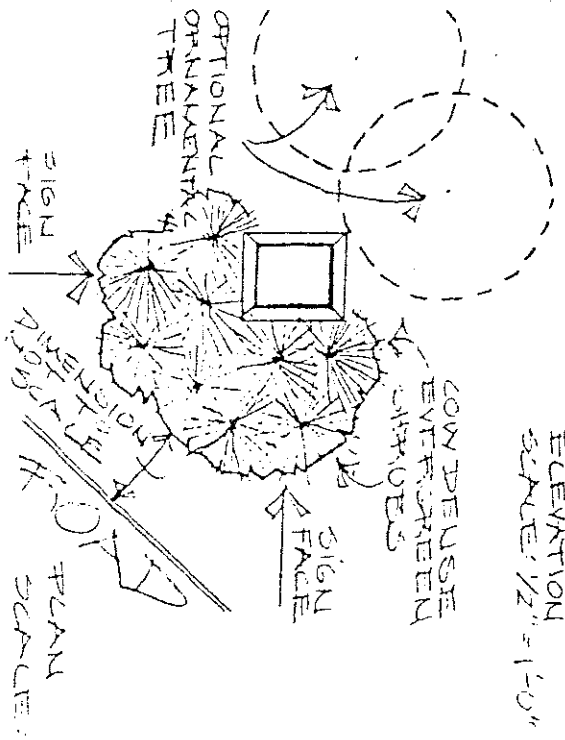
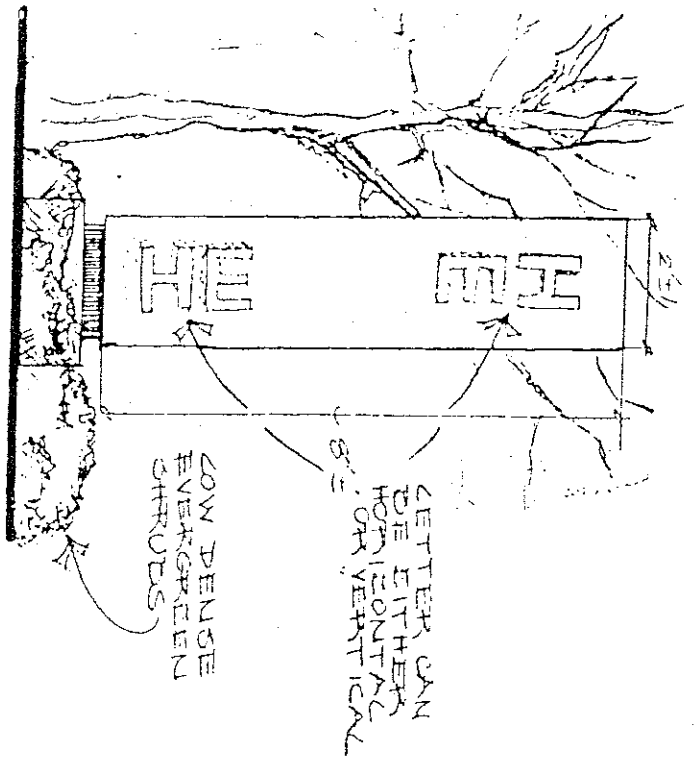

LANDSCAPE ARCHITECTS: LADA COLLINSVILLE, CONNECTICUT

NOTES:

1. RELATES TO CONTEMPORARY DESIGN BUILDING OR BUSINESS CENTER,
2. SIGN TO FACE EITHER,
3. SIGN SHOULD RELATE TO SCALE OF BUILDING SIZE BUILDING OR SITE,
4. SIGN SET IN LANDSCAPED ISLAND OR FRONT YARD,
5. PLANTING AREA TREE GUARDED WITH LANDSCAPED BARRIERS, SEE PLAN,
6. COLORED AND MATERIALS TO COMPLEMENT BLDG. DESIGN,
7. MATERIALS CONSIDERED,
8. METAL OR FIBERGLASS FACE COMPLETE BARGE ATTACHED TO SURFACE OR ENGRAVED, ETCHED, OR CARVED,
9. VERTICAL SIGN MAY REQUIRE OPTIONAL ORNAMENTAL TREES,

CONTEMPORARY 2' x 5' VERTICAL

FREESTANDING SIGN 9  
 DESIGN ALTERNATIVES  
 CANTON CHAMBER OF COMMERCE

DICK SINGER,  
 PRESIDENT  
 CHARLES...  
 JACK ST PIERRE,  
 CHAIRMAN ROUTE 44  
 SIGN COMMITTEE

DATE:  
 NOV 30, 198

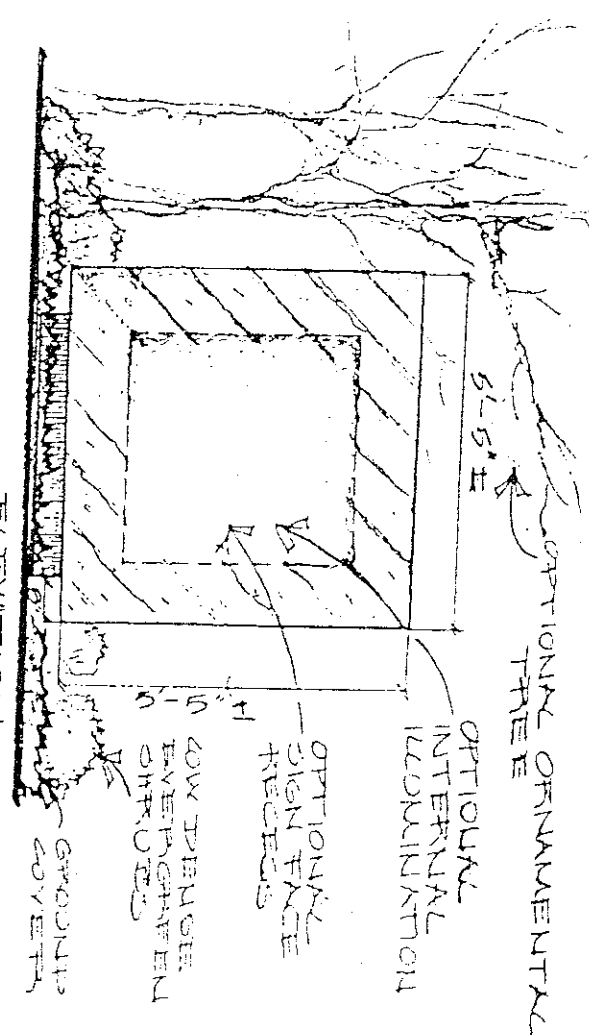

ELEVATION  
SCALE: 1/2" = 1'-0"

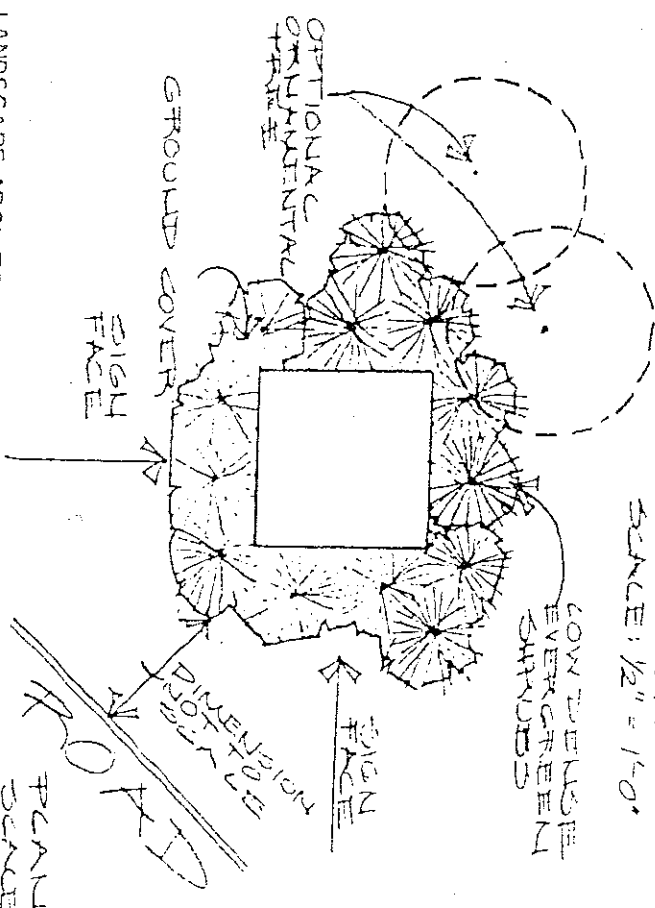

LANDSCAPE ARCHITECTS: LADA COLLINSVILLE, CONNECTICUT  
PLAN SCALE: 1/4" = 1'-0"

NOTES:

1. FREESTANDING TO CONSIDER ALTERNATIVE DESIGN SOLUTIONS FOR BUILDING CONSTRUCTION.
2. DESIGN TO BE APPROVED BY THE BOARD OF BUILDING OFFICIALS.
3. DESIGN TO BE APPROVED BY THE BOARD OF BUILDING OFFICIALS.
4. DESIGN TO BE APPROVED BY THE BOARD OF BUILDING OFFICIALS.
5. DESIGN TO BE APPROVED BY THE BOARD OF BUILDING OFFICIALS.
6. DESIGN TO BE APPROVED BY THE BOARD OF BUILDING OFFICIALS.
7. DESIGN TO BE APPROVED BY THE BOARD OF BUILDING OFFICIALS.
8. DESIGN TO BE APPROVED BY THE BOARD OF BUILDING OFFICIALS.
9. DESIGN TO BE APPROVED BY THE BOARD OF BUILDING OFFICIALS.
10. DESIGN TO BE APPROVED BY THE BOARD OF BUILDING OFFICIALS.

CONTEMPORARY  
5'-5" x 5'-5" SQUARE

FREESTANDING SIGN 10  
DESIGN ALTERNATIVES  
CANTON CHAMBER OF COMMERCE

DICK SINGER,  
PRESIDENT  
JACK ST PIERRE,  
CHAIRMAN ROUTE 44

DATE:  
JULY 31, 1984

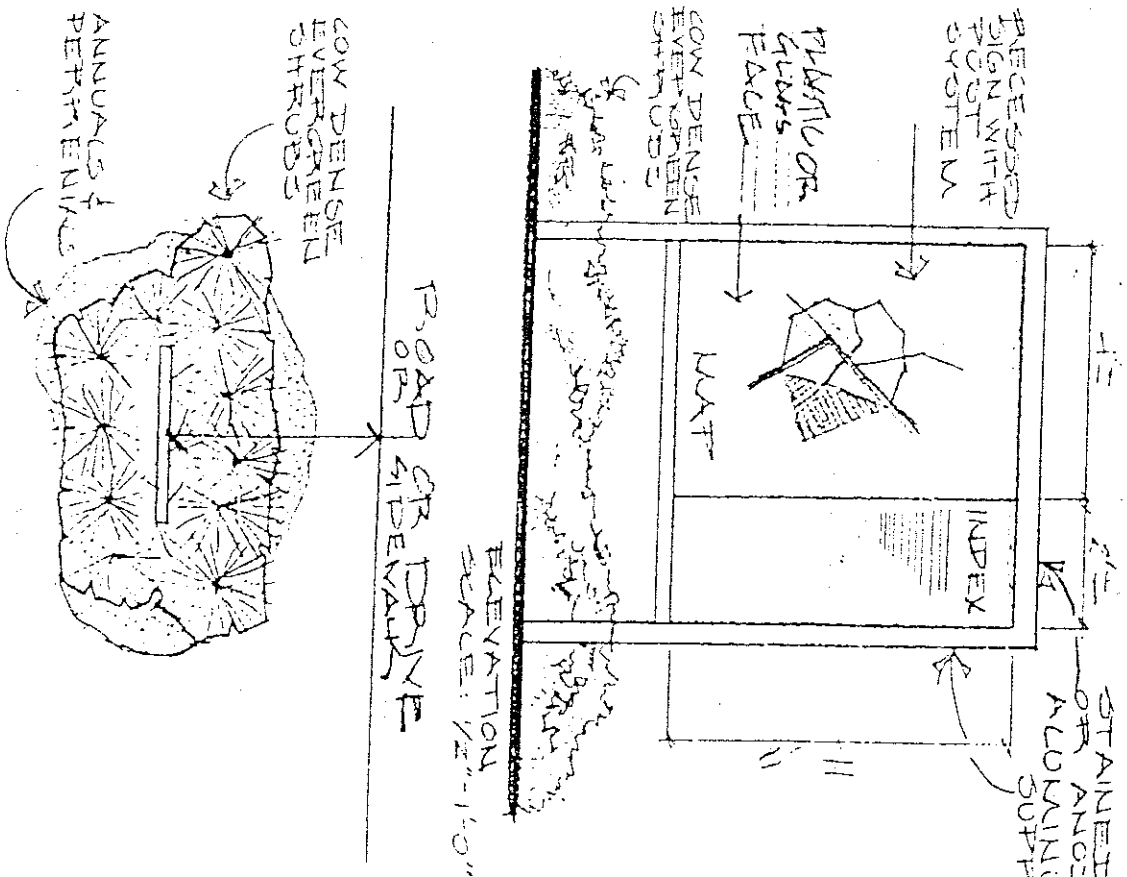

LANDSCAPE ARCHITECTS: LADA COLLINSVILLE, CONNECTICUT

PLAN SCALE: 1/4" = 1'-0"

**NOTES:**

1. PREPARED TO CONSTITUTE A PRIMARY DESIGN BUILDING OR BUILDING CONTRACT.
2. SIGN TO FACE EITHER INTERIOR, EXTERIOR OR SIDEWALK.
3. SIGN SIZE SHOULD RELATE TO MEDIAN OR LARGE SIDEWALK BOUNDARY.
4. PAINTING AREA REQUIRED; SOLO, ET.
5. COLORS AND MATERIALS TO COMPLEMENT BUILDING DESIGN.
6. MATERIALS CONSIDERED:
  - A. WOOD, METAL, OTHER
  - B. FIBER GLASS FACE, WOOD OR ALUMINUM SUPPORTS.
  - C. LETTERING TO BE ATTACHED TO SURFACE OR ENGRAVED, ETCHED, OR CARVED.

**CONTEMPORARY INDEX MAP**

FREESTANDING SIGN 11  
DESIGN ALTERNATIVES

BUCK SANGER,  
ARCHITECT  
CHARTERED ARCHITECT  
JACK ST. PIERRE,  
LANDSCAPE ARCHITECT

DATE:  
JULY 30,

TOWN OF CANTON  
ZONING COMMISSION  
SIGN PERMIT APPLICATION

( ) Wall or other attached sign ( ) Ground Sign: ( ) permanent  
( ) temporary

Location: \_\_\_\_\_

If commercial, Business Name: \_\_\_\_\_

Property Owner: \_\_\_\_\_

Address: \_\_\_\_\_

Applicant: \_\_\_\_\_

Address: \_\_\_\_\_

If temporary ground sign:

Dimensions: \_\_\_\_\_

Sign to be posted from \_\_\_\_\_ to \_\_\_\_\_

If permanent ground sign or wall sign:

Dimensions: \_\_\_\_\_

Zoning Commission approval date: \_\_\_\_\_

Application # \_\_\_\_\_ File # \_\_\_\_\_

To be completed by the Zoning Enforcement Officer

( ) Approved ( ) Denied Date: \_\_\_\_\_

Comments/Conditions:  
\_\_\_\_\_  
\_\_\_\_\_

\$25.00 up to 25 sq. ft.  
\$5.00 fee paid on \_\_\_\_\_ date ( ) cash ( ) check # \_\_\_\_\_  
Zoning Enforcement Officer

Off-Site Real Estate Directional Sign

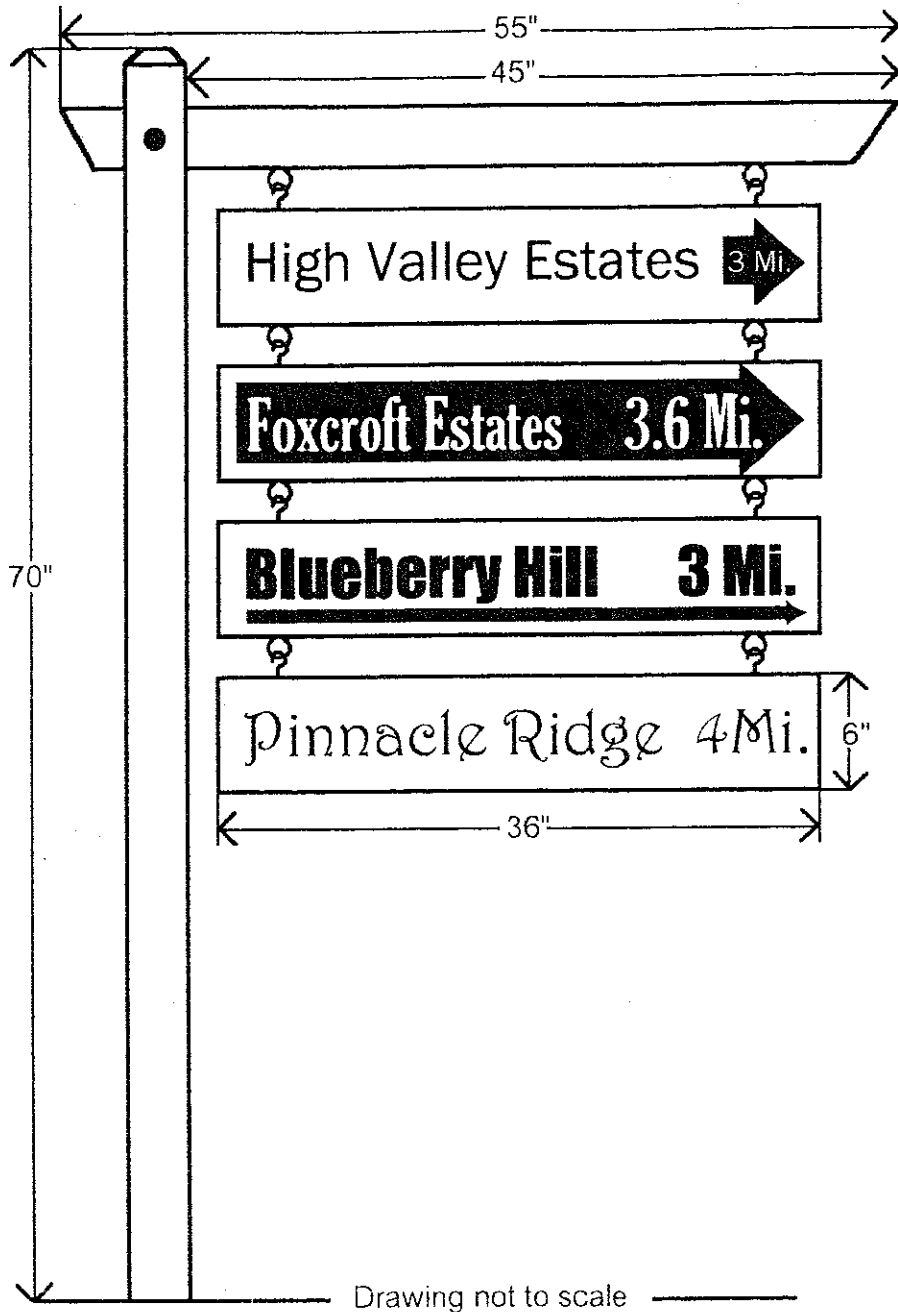

SUBMITTED

AUG 13 2002

LAND USE OFFICE

FILE 156 # 1991

PROMOTIONAL MODEL GROUND SIGN  
(Single Establishment)

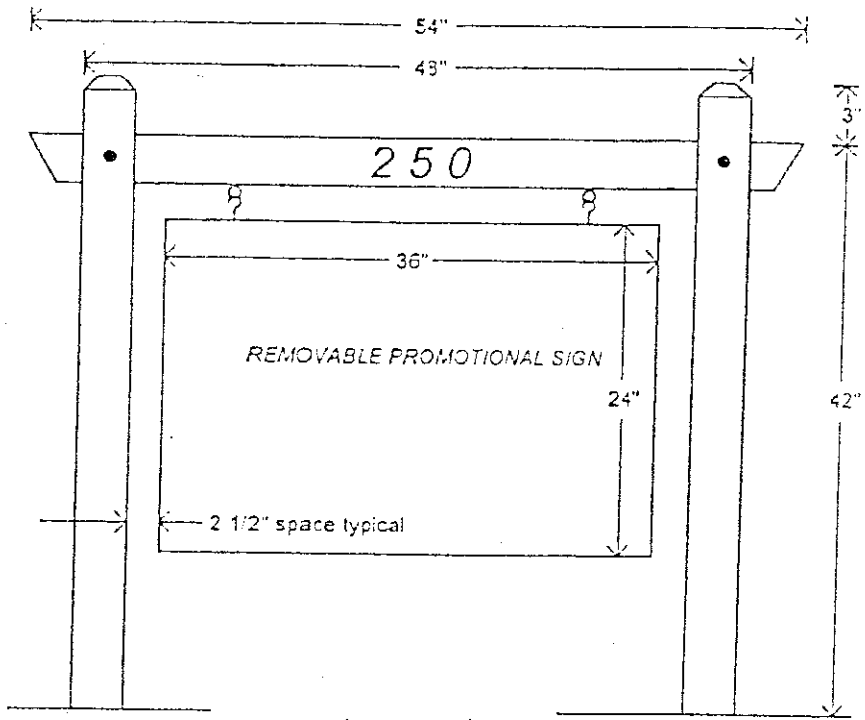

Drawing not to scale

PROMOTIONAL MODEL GROUND SIGN  
(Multiple Establishments)

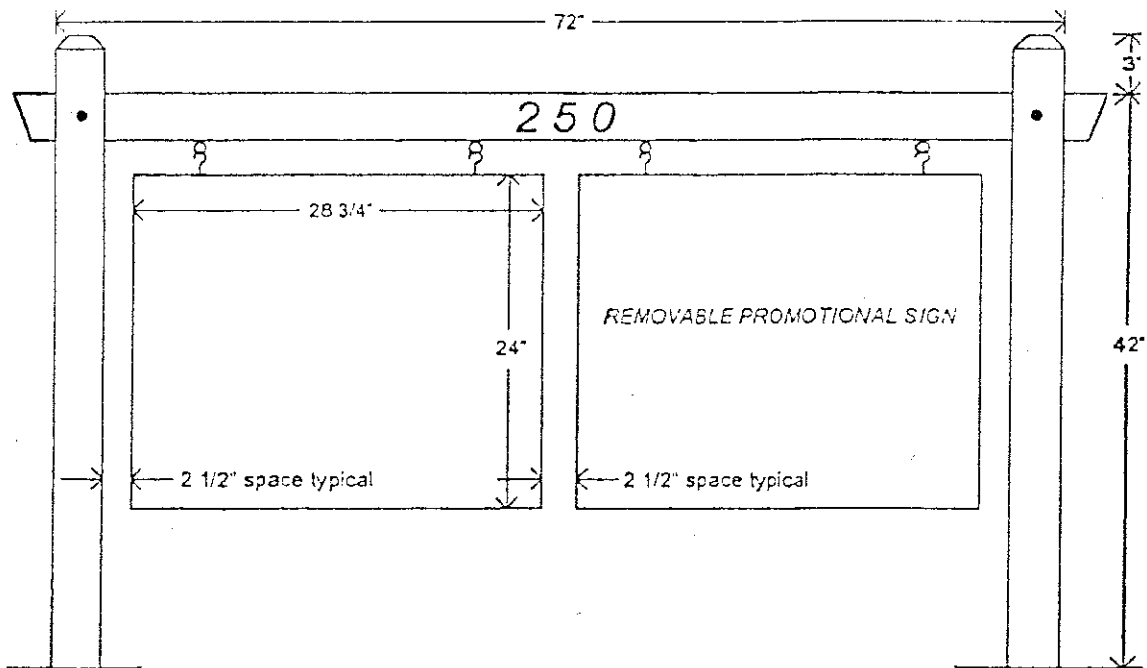

Drawing not to scale

WELCOME NEW BUSINESS MODEL GROUND SIGN

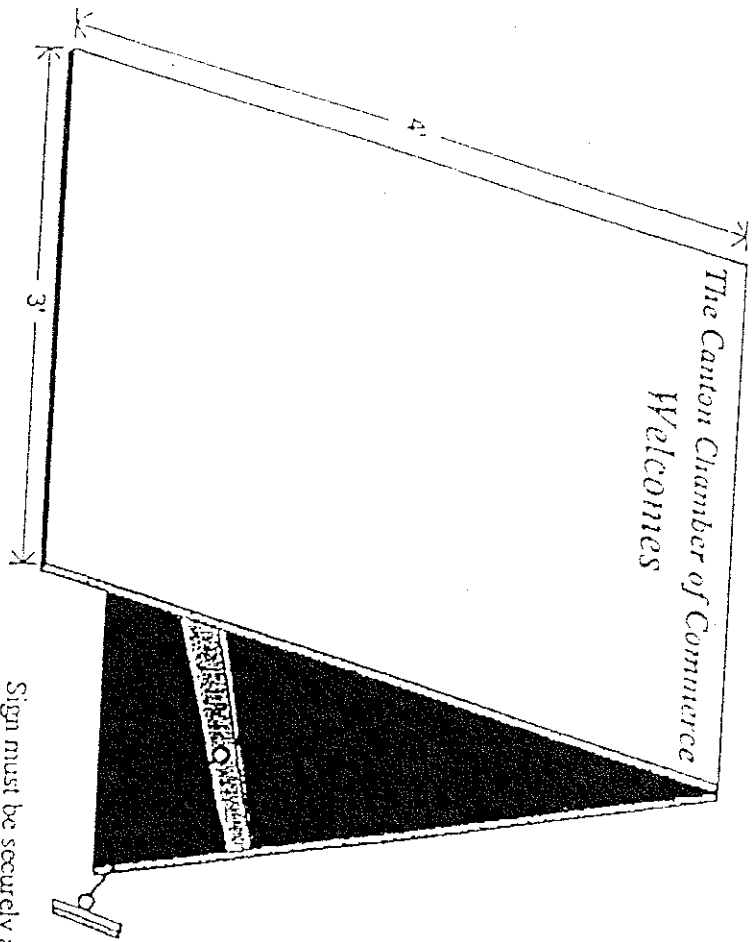

Drawing not to scale

Sign must be securely anchored for safety

LANDSCAPE ARCHITECTS. LADA COLLINSVILLE, CONNECTICUT

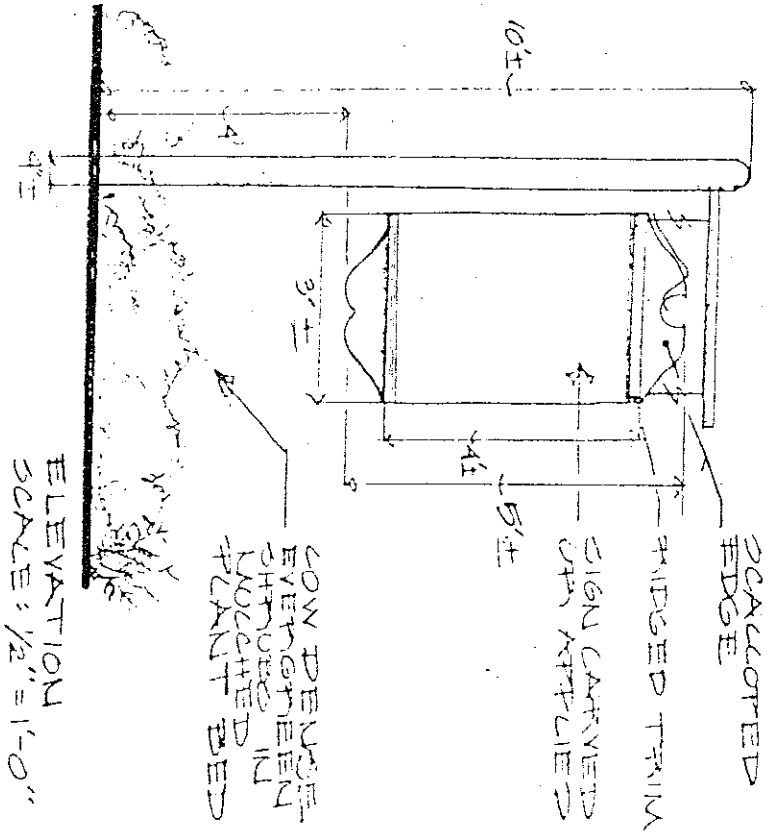
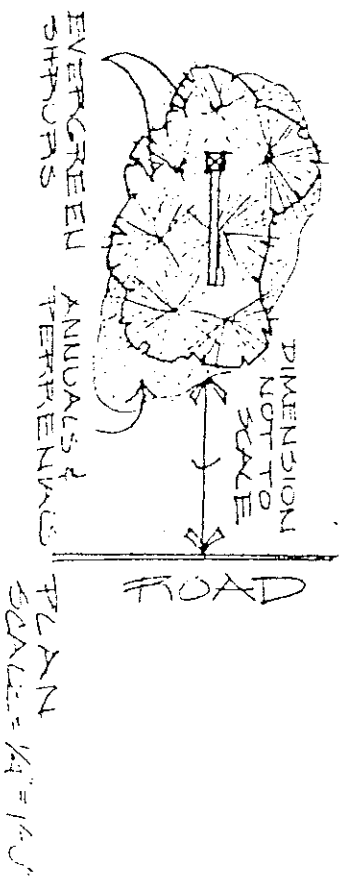

NOTES:

1. RELATES TO TRADITIONAL DESIGN BUILDING OR BUILDING COMPLEX.
2. SIGN TO FACE EITHER ROAD OR PARKING AREA
3. SIGN SHOULD RELATE TO SPACE BUILDING OR SITE SIZE,
4. SIGN SET IN LANDSCAPED ISLAND OR FRONT YARD.
5. PAINTING AREA REQUIRED WITHIN LANDSCAPED YARD. 60 SQ.F.T. =
6. COLORS & MATERIALS TO COMPLEMENT BLDG. DESIGN,
7. MATERIALS CONSIDERED: STAINED OR PAINTED WOOD POSTS OR ANODIZED ALUMINUM POSTS. WOODEN SIGN PAINTED OR STAINED,
8. SIGN HUG FROM CROSS-BARR BY CHAIR OR WIRE,

TRADITIONAL DESIGN  
3'x5' SINGLE POST

FREESTANDING SIGN 1  
DESIGN ALTERNATIVES  
CANTON CHAMBER OF COMMERCE

DICK SANGER,  
PRESIDENT  
CHAMBER OF COMMERCE  
JACK ST PIERRE,  
CHAIRMAN ROUTE 44  
SIGN COMMITTEE

DATE:  
JULY 09, 198

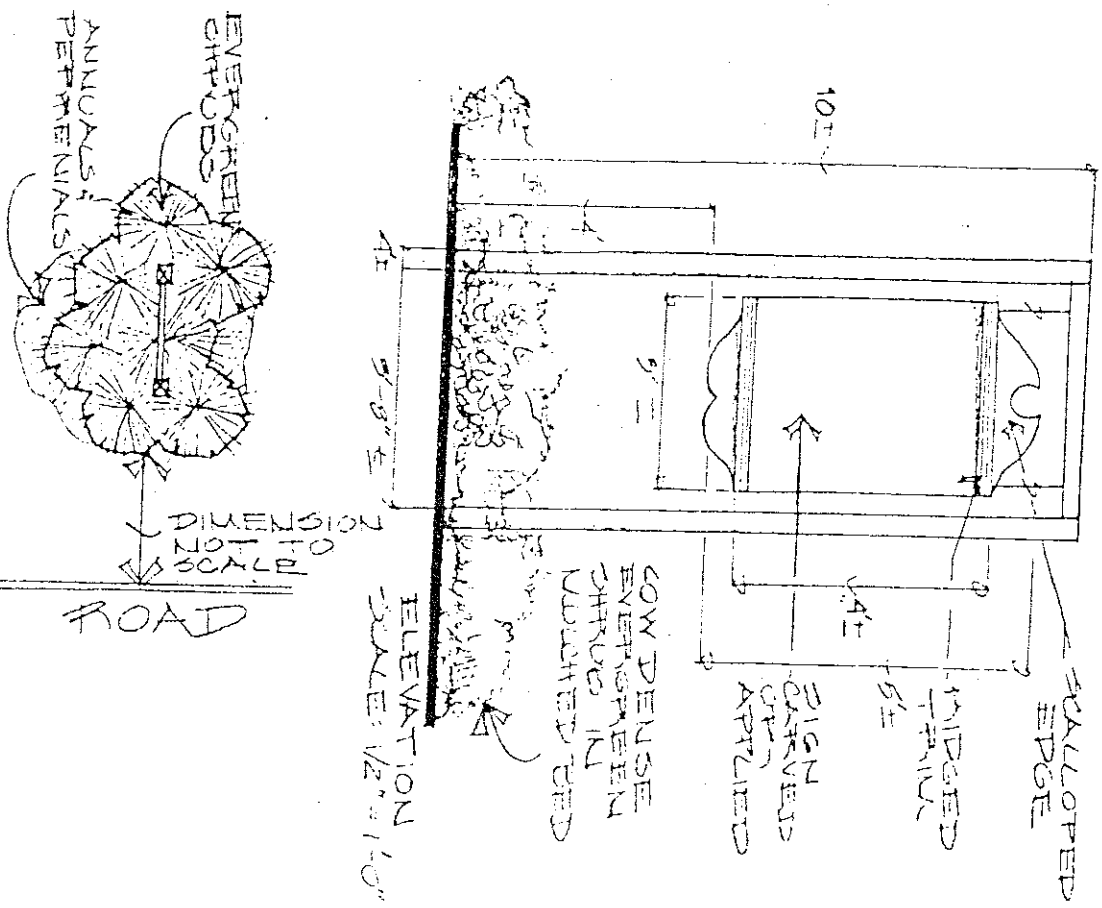

PLAN SCALE: 1/4" = 1'-0"

LANDSCAPE ARCHITECTS, LADA COLLINSVILLE, CONNECTICUT

NOTE 3:

1. VARIATION OF SIGN #1 RELATES TO TRADITIONAL DESIGN BUILDING OR BUILDING COMPLEX.
2. SIGN TO FACE EITHER ROAD OR PARKING AREA.
3. SIGN SHOULD RELATE TO SMALL BUILDING OR SITE SIZE.
4. SIGN SET IN LANDSCAPED AREA OR FRONT YARD.
5. PAINTING AREA REQUIRED WITHIN LANDSCAPED AREA, 60 SQ. FT.
6. COLOURS & MATERIALS TO COMPLEMENT SIGNS DESIGN.
7. MATERIALS CONSIDERED, STAINED OR PAINTED, WOOD POSTS OR ANODIZED ALUMINUM POSTS, WOODEN SIGN PAINTED OR STAINED.
8. SIGN HUNG FROM CROSS-BARK BY CHAIN OR WIRE.

TRADITIONAL DESIGN 3'x5' DOUBLE POST

FREESTANDING SIGN 2  
 DESIGN ALTERNATIVES  
 CANTON CHAMBER OF COMMERCE

DICK SANGER,  
 PRESIDENT  
 CHAMBER OF COMMERCE  
 JACK ST PIERRE,  
 CHAIRMAN, ROUTE 44  
 SIGN COMMITTEE

DATE:  
 JULY 30, 1988

LANDSCAPE ARCHITECTS: LADA COLLINSVILLE, CONNECTICUT

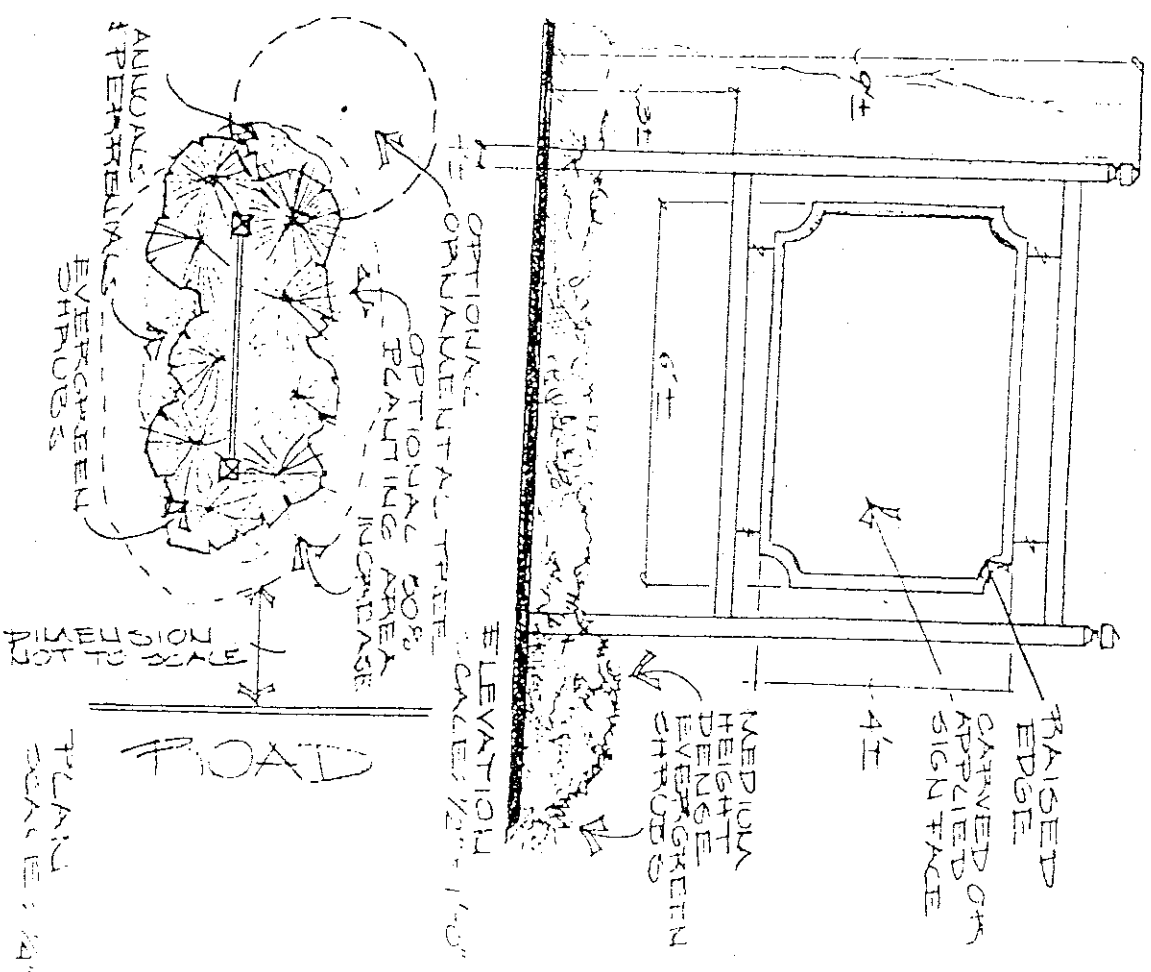

NOTES:

1. RELATES TO TRADITIONAL DESIGN BUILDING OR BUILDING COMPLEX,
2. SIGN TO FACE EITHER ROAD OR PARKING AREA,
3. SIGN SHOULD RELATE TO MEDIUM BUILDING OR SITE SIZE,
4. SIGN SET IN LANDSCAPED ISLAND OR FRONT YARD,
5. PLANTING AREA REQUIRED WITHIN LANDSCAPED YARD: 100 SQ. FT. =
6. COLORS AND MATERIALS TO COMPLEMENT BLDG. DESIGN,
7. MATERIALS CONSIDERED: STAINED OR PAINTED WOOD POSTS OR ANODIZED ALUMINUM POSTS, WOODEN SIGN PAINTED OR STAINED,
8. SIGN HUNG FROM CROSS-BAR BY CHAIN OR WIRE, AND ATTACHED TO LOWER END OF SIGN IN A DIVULGATE FASHION. SIGN WILL NOT SWING,

TRADITIONAL DESIGN  
4'x6' DOUBLE POST

FREESTANDING SIGN 3  
DESIGN ALTERNATIVES  
CANTON CHAMBER OF COMMERCE

DICK SANGER,  
PRESIDENT  
CHAMBER OF COMMERCE  
JACK ST PIERRE,  
CHAIRMAN ROUTE 44  
SIGN COMMITTEE

DATE:  
JULY 30, 1988

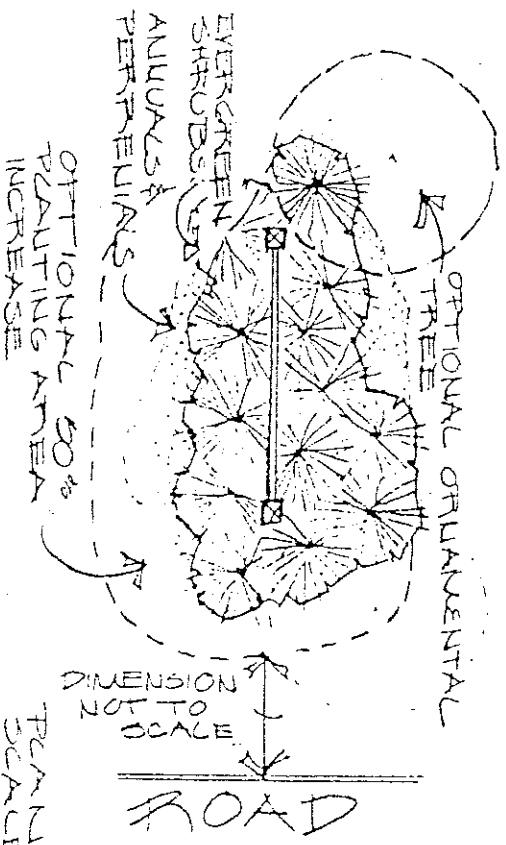
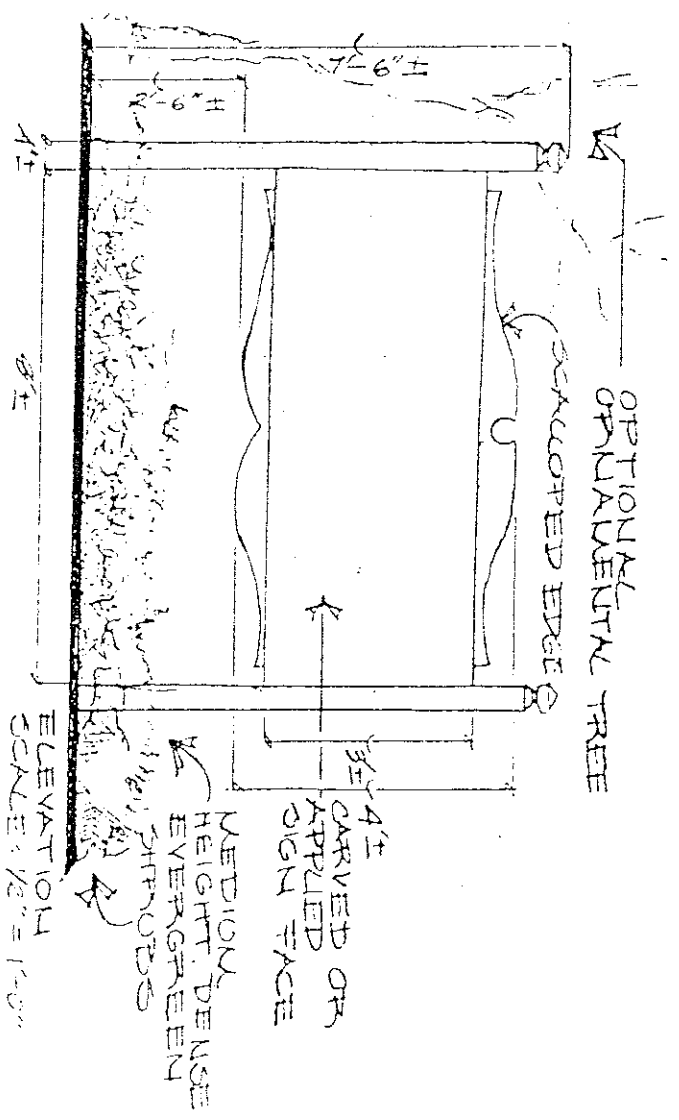

LANDSCAPE ARCHITECTS: LADA COLLINSVILLE, CONNECTICUT

NOTES:

1. RELATES TO TRADITIONAL DESIGN BUILDING OF BUILDING COMPLEX,
2. SIGN TO FACE EITHER ROAD OR PARKING AREA
3. SIGN SHOULD RELATE TO CURVE BUILDING OR CURVE SIDE,
4. SIGN SET IN LANDSCAPED AREA OR FRONT YARD,
5. PAINTING AREA REQUIRED WITHIN LANDSCAPED YARD: 130 SQ. FT.,
6. COLORS AND MATERIALS TO COMPLEMENT BLDG. DESIGN,
7. WATERFURNUS CONSIDERED; STAINED OR PAINTED WOOD POSTS OR ADOLIZED ALUMINUM POSTS; WOODEN SIGN PAINTED OR STAINED,

TRADITIONAL DESIGN  
4' X 8' DOUBLE POST

<p>FREESTANDING SIGN 4 DESIGN ALTERNATIVES CANTON CHAMBER OF COMMERCE</p>	<p>DICK SANGER, PRESIDENT CHAMBER OF COMMERCE JACK ST. PIERRE, CHAIRMAN ROUTE 44</p>	<p>DATE: JULY 30, 19</p>
---	--	------------------------------